



Q Series Fan Filter Units



Switch Detail
115V/277V

Product Specifications	2
Safety Instructions	3
Receiving and Unpacking	3
Pre-Installation Instructions	3-4
Installation Instructions	4
Electrical Installation Instructions	5
Operation Instructions	6
Troubleshooting Guide and PM Instructions	7
When to Change the HEPA or ULPA Filter	8
Wiring Diagram	9
Warranty	10

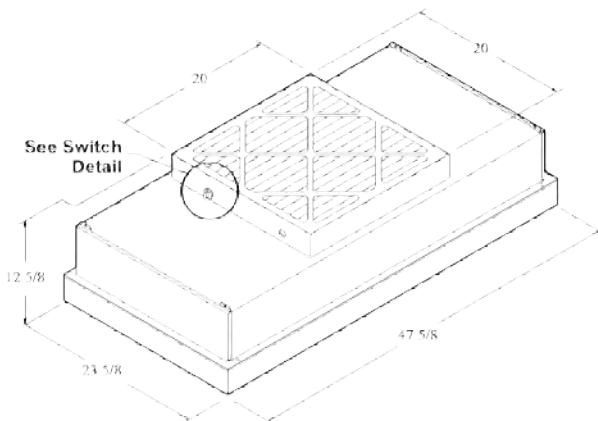
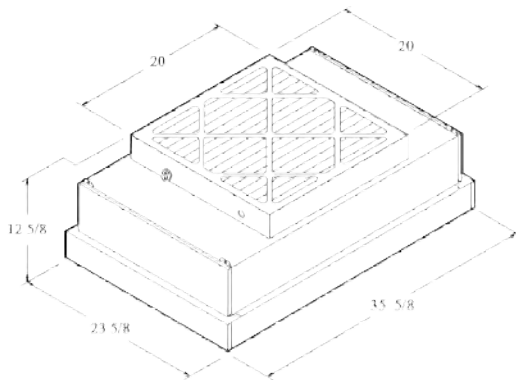
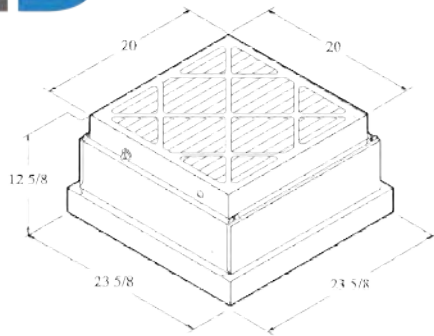

Switch Detail
115V/277V

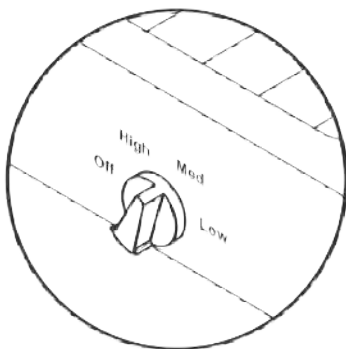

Motor Data								
Motor	Volt	HZ	Amps			Start-Up Amps		
			Low	Med	High	Low	Med	High
1/5 HP	115	60	1.45	1.95	2.85	1.70	2.60	5.0
1/5 HP	277	60	.52	.71	1.1	.60	.85	1.5

(1) Line voltages can affect actual start-up amperage

(2) Use standard NEC tables for sizing circuits

Q Series Filter Data: The HEPA Filter is designed for 90 FPM average face velocity @ initial 0.47 w.g. and has a rated efficiency of 99.99% @ 0.3 micron or larger.

Optional Access Port: This port is located in the center of the filter element face and is used for introducing an upstream challenge or measuring static pressure.

Air Flow: 340 to 640 CFM Range for a 2' x 4' unit and 220 to 340 CFM Range for a 2' x 2' unit. At 90 FPM, CFM is nominal 510 on a 2' x 4' and 220 on a 2' x 2' unit.

Ceiling Size: All 2' x 4' models are designed to fit a nominal 2' x 4' ceiling grid with a 22.5" x 46.5" standard opening

Sound Level: 50-52 dba with less than 45 dba of ambient sound @ 90 FPM measured 30" from face of filter.



Safety Instructions

Before servicing or cleaning this unit you need to switch the power off at the service panel, and then lock the service disconnecting means to prevent the power from being switched on accidentally. When the service disconnecting means cannot be locked, securely fasten a prominent warning device, such as a tag, to the service panel.

The Q Series Fan Filter Units are suitable for commercial and industrial use only.

They are designed for suspended installation or installation in T-Grid Ceiling Systems for Vertical Flow.

Do not place anything on top of the units or restrict the flow of air into the unit, and never expose them to water, ice, snow, or extensive moisture.

Receiving and Unpacking

All shipments are “FOB Ship Point”. This means once goods are picked up and signed for by the driver, they are the responsibility of the freight company. When the shipment is delivered and signed for by your receiving personnel, the ownership and responsibility is transferred to the receiving company.

Bennett & Bennett Inc. inspects each product before packaging and does not ship damaged goods. Inspect the incoming shipment with the freight carrier driver present. Note any suspected damage on the receiving papers and immediately inspect the damaged carton(s). Note damages on the receiving documents and file a freight claim with the transportation company. Bennett & Bennett does not take responsibility for damages caused by the freight company.

If damage is discovered after the carton is opened, it is the buyer’s/receiver’s responsibility to file a freight claim. Keep all incoming cartons and the product for inspection. Do not send back to Bennett & Bennett.

Pre-Installation

Installation work and electrical wiring must be done by qualified person(s) in accordance with all applicable codes and standards, including fire-rated construction.

Q Series Fan Filter Units operate on 115 Volts, 277 Volts at 60 Hz. Check the label on the front of the unit for voltage, current and frequency of operation. Verify the rating of the branch circuit wiring prior to installation

CORPORATE OFFICES: 888 Dayton Street Suite 105, Yellow Springs, OH 45387

TOLL FREE: (888) 423-6638

FAX: (937) 324-8753

E-MAIL: sales@bennettbnennett.com



and electrical connection to the unit.

Certain models are provided with an optional flexible power cord with plug. Do not use any type of adapter that will allow the unit to be plugged into an outlet that is not grounded.

Do not plug the unit into an outlet that is controlled by an on/off wall switch or by a facility house lighting control switch.

Caution: To reduce the risk of injury to persons, install the unit at least 7 feet above grade or in ceiling.

Installation Instructions

HEPA and ULPA filter media is fragile and can be damaged easily. Special precautions must be taken during unpacking and installation of Q Series Fan Filter Units to avoid damage to the filter media. **TOUCH ONLY THE FRAME AND DO NOT PLACE HANDS OR ANY OTHER OBJECTS ON THE FILTER SURFACE.**

Commercially available 1" or 1 - 1/2" T-Grid suspended ceiling systems are not designed to support the weight of any fan powered filter units. Bennett & Bennett supplies 2" T-Grid systems for softwall and hardwall cleanrooms that do provide the support necessary for direct mounting of Q Series Filter Fan Units.

If 2" T-Grid system is not installed, it is mandatory that Q Series Fan Filter Units be suspended independently from these suspended ceilings

Mechanical installation of Suspended Vertical Flow Units: Q Series Fan Filter Units are equipped with attachment points to make the installation hanging process easy. Units may be supported with flexible or rigid hangers. Use at least 12-gauge hanging wire for the equivalent light chain or cable on each corner to support the unit.

Mechanical Installation of Units in 2" T-Grid Systems: Install 2" T-Grid system in accordance with site plan and manufacturers instructions. Install seal gaskets (if provided) in pre-designated locations. Carefully place Q Series Fan Filter Unit into the grid opening taking care to not damage the filter media while handling the units.



Electrical Installation

Provision of electrical branch circuit supply to the appropriate location within close proximity to the Q Series Fan Filter Units is the responsibility of the customer's electrical installer. If local or national electrical codes or the customer's installation specifications require the provision of metal conduit directly to the unit it is recommended that UL Listed flexible metal conduit be provided.

Q Series Fan Filter Units may be supplied with optional flexible power cords with grounded plug, optional 2" x 4" or 4" x 4" metallic wiring boxes with covers, with or without a power switch mounted in the wiring box or optionally within the pre-filter frame housing. When a power switch is provided, field connections are to be made directly to the open supply of terminals of the switch. When a power switch is not provided, field connections are to be made to the non-connected pigtail leads within the metallic wiring box or pre-filter frame.

CAUTION: When making field wiring connections within the Pre-Filter Frame, make sure that all field installed wiring is routed away from moving motor and fan parts and is secured in place to prevent inadvertent damage to wires.

Start-up Check List-Before Applying Power:

Check the voltage on the Name Plate and verify that the power supplied to the unit is the same as that listed on the Name Plate. Remove the Pre-Filter and determine if the fan is free to rotate and has not been misaligned during shipment or installation. Check nuts, bolts, screws, and electrical connections for tightness.

CAUTION: If the unit is provided with a square perforated metal barrier over the opening to the Pre-Filter Frame, it must be installed again prior to application of power and startup of the Fan Filter Units.

Apply power and check that the wheel is rotating in the correct direction. Looking through the Pre-Filter Frame the fan must be rotating in a clockwise direction.



Operation Instructions

Q Series Fan Filter Units are self-contained, low profile, electric powered, motor-fan driven HEPA or ULPA Filter, air filtering appliances. The units are heavy-duty units suitable for many industrial / commercial applications where clean air is needed. This is accomplished by maintaining a flow of filtered air to remove airborne particles within an enclosed room or chamber. Where manufacturing and assembly processes require Federal Standard 209 or ISO Classification clean rooms, multiple Q Series Fan Filter Units can provide a sufficient number of filtered air changes to maintain a positive pressure of clean air within the controlled environment.

Because of the unique variety of sizes and options offered, Q Series Filter Fan Units can be incorporated into many different areas such as Softwall Cleanrooms, new Hardwall Cleanroom designs, and facility upgrades over conveyors or free standing machinery. They may also be incorporated into custom workbench constructions providing concentrated filtered air to meet critical clean air process requirements.

Method of Operation

Unfiltered air is drawn into the air inlet at the top of the unit through an optional 20" x 20" Pre-Filter. This air is pulled through the motor / blower assembly into a plenum designed to evenly distribute air over and through the entire receiving surface of the HEPA Filter. Thus, Q Series Fan Filter Units efficiently and quietly deliver the desired volume of cleaned air to the controlled environment. The volume of air delivered can be adjusted by means of a factory installed 3-speed switch.



Troubleshooting Guide:

Problem: Blower Doesn't Run

Possible Solution:

1. Make sure the unit is properly connected to the power source.
2. Make sure the 3-speed switch is in the high, medium, or low position.
3. Verify that there is power running to the outlet.
4. Check the capacitor for loose connection.

Problem: Blower is running, but no or very little air flow is being generated:

Possible Solution:

1. Make sure the blower is running clockwise as viewed through the Pre-Filter Frame and Blower Opening.
2. Pre-Filter is dirty and should be replaced.
3. HEPA Filter is dirty and should be replaced.

Preventive Maintenance (PM) Instructions

To ensure optimum safe performance and maximum product life you should have a preventative maintenance program.

1. Inspect the Pre-Filter, HEPA or ULPA Filter after the first three (3) months of operation. Based on the findings, schedule periodic inspections and maintenance for changing the Pre-Filter and the HEPA or ULPA Filters.
2. Pre-Filters should be changed at least every six (6) months.
3. Cleaning the fan wheel is required to ensure smooth quiet operation. Periodic cleaning of all fan equipment is strongly recommended because dirt accumulation on the propeller can cause vibration increases stress and load on motor bearings.
4. Order replacement filters from Bennett & Bennett on the web or contact us toll free at (888) 423-6638



When to Change the HEPA or ULPA Filter

Static pressure can be measured with a Magnehelic gauge or manometer. If the resistance to pressure drops across the filter at twice the original resistance it is time to change the filter.

Tools Required:

1. Power driver, 1/4" socket bit
2. Standard slotted screw driver

How to Change the HEPA or ULPA Filter:

1. Remove the Q Series Fan Filter Unit from the ceiling, and place it on a solid surface.
2. Use a power driver and 1/4" socket bit or, Phillips head screwdriver, remove twelve Self-Piercing Screws located on the plenum flange.
3. Separate the plenum hood assembly from filter.
4. Clean the plenum flange surface.
5. Place plenum hood assembly on top of the replacement filter.
6. Install all Self-Piercing Screws and place the Q Series unit back into the ceiling.



Wiring Instructions

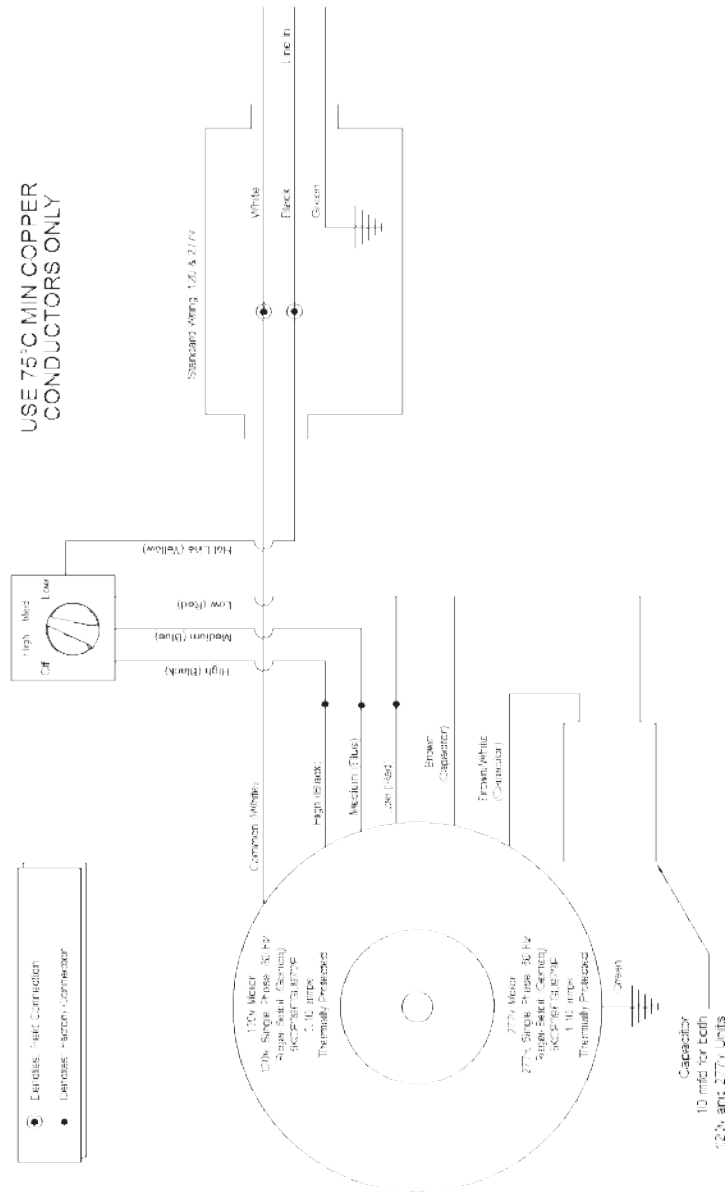



Bennett & Bennett Product Warranty

Bennett & Bennett warrants this equipment to be free from defects in material and workmanship for a period of one (1) year from the date of shipment.

No other warranty is herein expressed and none shall be implied.

If failure appears within one (1) year from date of purchase, the buyer must notify Bennett & Bennett immediately. Documentary proof of length of service (which shall include date of purchase) must be furnished to Bennett & Bennett if the date of manufacture was more than one (1) year prior to the date of alleged failure. Defective product may be delivered freight prepaid to the nearest Bennett & Bennett authorized location. Bennett & Bennett shall, at its option, correct the defect, or supply a replacement.

The liability of Bennett & Bennett shall not in any case exceed either the cost of correcting defects in the product or supplying a replacement for that, whichever shall be less, and upon the expiration of one (1) year from the date of shipping by Bennett & Bennett all such liability shall terminate.

Bennett & Bennett is not responsible for damage to the product due to abuse, improper installation, use other than for which it was sold, or through operation above rated load, either intentionally or otherwise of any party. Under no circumstances will Bennett & Bennett be responsible for any freight (in or out), installation, or removal costs.

The foregoing warranty is in lieu of all other warranties, express or implied, with respect to the product, including any implied or statutory warranty of merchantability or fitness for purpose. Bennett & Bennett shall not be liable by virtue of this warranty, or otherwise, for any consequential, incidental or special loss or damage resulting from the use or loss of use of the product.